



Contribute To The VIE

The VIE loves continuing stories. This issue has continuations or additions on Leap Year, Remington-Rand cards, the famous 1952 election and on Roberto Guatelli, the amazing model builder.

Eric Petrich's article on his experience with computers and leap year might have been entitled "Back In The Day." Let us have your "Back In The Day" story.

Share your stories and expertise with your colleagues.

And ask your questions. We may not always get answers but the conversations are always interesting.

Jim Strickland jlstrick@aol.com

Colleagues –

I'm pleased to relay an announcement, by Kirsten Tashev, that the executive team has decided to extend the Jim Williams display (An Analog Life) until September 15, 2012.

Cheers, Jim McClure

In Memoriam

Larry Welke 1931 - 2012

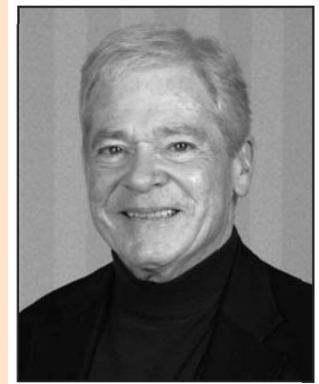

Founder of International Computer Programs and one of the most influential people during the first 20 years of the growth of the software industry, died in Carmel, Indiana on March 3, 2012 after a long battle with cancer.

Larry was the world's first publisher dedicated to the newborn software industry. His belief in the viability of software as a product and his continuing advocacy for the emerging industry were crucial factors in the increasing acceptance and credibility of the software industry.

The VIE Cumulative Index is stored at:

http://s3data.computerhistory.org.s3.amazonaws.com/chmedu/VIE-000_Cumulative_Topic_Index.pdf

CONTENTS

VIE	1
In Memoriam: Larry Welke	1
More on Rem Rand Cards	1
More on Leap Year	2
Three Comments from Mike Albaugh	2
"Dr. Seuss" Explains Computers	2
More on Roberto Guatelli	3
Minuteman Computer	4
ABC and the 1952 Election	5
Coming Events	5

MORE ON REM RAND CARDS

ED THELEN

In 1962, (before I claim I was born) when entering the Pennsylvania Turnpike I was given a round holed data card (from Remington Rand Univac equipment, which had the contract).

On exiting from the turnpike, you turned in the card and were billed for the distance you drove..

Some spoil-sports reported that if you didn't take long enough between entrance and exit, you would receive a speeding ticket, with the holes in the data card as evidence against you.

MORE ON LEAP YEAR

ERIC PETRICH

My job in the Navy involved maintaining the special-purpose computers for SOSUS, the strategic sonar system used to keep track of Soviet ships and subs. The vast majority of this was done on shore; in my six years in the Navy, I never served on board a ship. Despite the distinct lack of seawater, we still had quite a few systems using the AN/UYK-20 ("yuck-twenty") general-purpose computer, designed for shipboard installation.

This was slowly changing, however, and my duty station was fitted out with a replacement for one system, now based around a SPARC computer. All well and good, until 31 March, 1992. At midnight GMT (or 0000Z) I was the duty technician unlucky enough to be told that the system had stopped working correctly. Not a crash or anything demonstrably bad, just a failure to do one simple thing that rendered it useless.

Our troubleshooting duties were fairly empirical, so there was no way to delve into the code (even if I had been qualified). After exhausting my repertoire of potential fixes, I learned that other sites using this system were also off-line, and had been so since midnight GMT. Plainly this was above my paygrade.

I went off duty the next morning, and I later learned that the system began working correctly again at (you guessed it) midnight GMT the next day. No explanation for the 24-hour hiccup ever reached my ears.

Here's the speculation: Many things done in the Navy use Julian dates, where January 1 is 001, February 1 is 0032, and so on. The Julian date for 31 March in 1992 was 091, but 1992 was a leap year. Any other year, and 091 would have been April 1.

THREE COMMENTS

MIKE ALBAUGH

- 1) "block sorting" was pretty common, especially if your tab-room had more than one sorter, because once the first pass was done, subsequent ones could be run in parallel on multiple sorters.
- 2) The (in)famous SPR 11-60903 tells you more than you might want to know about leaping. The top result for "Leap year SPR" was (for me): <http://www-users.cs.york.ac.uk/susan/joke/decly.htm> although the canonical location is apparently: <http://h71000.www7.hp.com/openvms/products/year-2000/leap.html> (which was top result for "SPR 11-60903")
- 3) If I recall correctly, the patch whereby Windows (probably the DOS-based, rather than VMS-ish NT ones) learned that 2000 was a leap year came out in November 1999. Some folks take a while to get the message.

"DR. SEUSS" EXPLAINS COMPUTERS

If a Packet hits a pocket on a socket on a port
And the bus is interrupted as a very last resort
And the address of the memory makes your floppy
disk abort
Then the socket packet pocket has an error to report.
If your cursor finds a menu item followed by a dash
And the double-clicking icon puts your window in the
trash
And your data is corrupted 'cause the index doesn't
hash
Then the situation's hopeless and your systems
gonna crash!
If the label on the cable on the table at your house
Says the network is connected to the button on your
mouse

But your packets want to tunnel on another protocol
That's repeatedly rejected by the printer down the
hall
And your screen is all distorted by the side effects of
gauss
So your icons in the window are as wavy as a souse
Then you may as well reboot and go out with a bang
'cause as sure as I'm a poet, the sucker's gonna
hang!
When the copy of your floppy's getting sloppy on the
disk
And the microcode instructions cause unnecessary
risk
Then you have to flash your memory and you'll want
to RAM your ROM
Quickly turn off the computer and be sure to tell your
mom.

MORE ON ROBERTO GUATELLI – THE AMAZING MODEL BUILDER

JIM STRICKLAND

In a recent VIE we discussed Dr. Roberto Guatelli and his replicas that add so much to the CHM (the Hollerith tabulator and sorter, the Pascaline, the Difference Engine No 1 model, and more). There is an additional chapter in his story.

On February 13, 1967 an amazing discovery was made by American scientists working in the National Library of Spain in Madrid. They chanced upon two unknown works of Leonardo da Vinci, now known as the "Codex Madrid." There was much excitement regarding this discovery and public officials stated that the manuscripts "weren't lost, but just misplaced."

In 1967, after the discovery, Dr. Guatelli flew to Massachusetts University to study its copy. Upon seeing the page with the adding machine he remembered seeing a similar drawing in the "Codex Atlanticus". He built the replica in 1968 combining the two drawings.

Previously, IBM had hired Guatelli to build da Vinci (and other) such replicas. They had organized a travelling tour of machines, which was displayed at schools, offices, labs, museums and galleries. The "Codex Madrid" replica was shown in the IBM exhibition.

The text beside the replica said:

Device for Calculation: An early version of today's complicated calculator, Leonardo's mechanism maintains a constant ratio of ten to one in each of its 13 digit-registering wheels. For each complete revolution of the first handle, the unit wheel is turned slightly to register a new digit ranging from zero to nine. Consistent with the ten to one ratio, the tenth revolution of the first handle causes the unit wheel to complete its first revolution and register zero, which in turn drives the decimal wheel from zero to one. Each additional wheel marking hundreds, thousands, etc., operates on the same ratio. Slight refinements were made on Leonardo's original sketch to give the viewer a clearer picture of how each of the 13 wheels can be independently operated and yet maintain the ten to one ratio. Leonardo's sketch shows weights to demonstrate the equability of the machine.

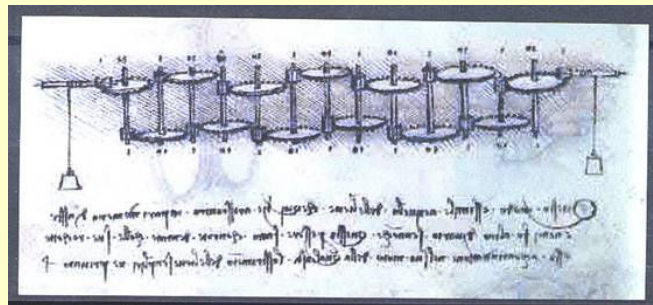

(Above) the drawing from Codex Madrid.

(Below) Guatellis model.



But there was controversy. The objectors claimed that Leonardo's drawing wasn't a calculator but more of a ratio machine. One revolution of the first shaft would give rise to 10 revolutions of the second shaft and 10 to the power of 13 at the last shaft. Such an engine couldn't be built due to the enormous amount of friction which would result. It was said that Dr. Roberto Guatelli "has used his own intuition and imagination to go beyond the statements of Leonardo".

After a year the controversy regarding the replica had grown and an Academic trial was held at the Massachusetts University in order to ascertain the reliability of the replica. Amongst others were present Professor I. Bernard Cohen consultant for the IBM collection and Doctor Bern Dibner a leading Leonardo scholar.

The vote was a tie, none the less IBM decided to remove the controversial replica from its display.

Roberto Guatelli died in September 1993 at the age 89. Where his famous replica is today, nobody knows. Possibly it is somewhere in one of IBM's storages but the IBM archivist doesn't think so.

MINUTEMAN COMPUTER

JIM STRICKLAND

For a long time I was puzzled by the Minuteman computer in our real-time exhibit. Every time I walked past, I would look at all the resistors and capacitors and wonder, "What was in the middle of the cylinder?" And, "Where is the computer?"

So I did a little research and found that the D17-B computer was part of the NS-IOQ1 Inertial Navigation System. The open space of the cylinder contained the "stable platform", which was composed of a support structure, gyros, velocity meters, gimbal motors, gimbal digital resolvers, an alignment set, a pitch transformation resolver and an excitation amplifier, all of which serve as a stable place to mount the inertial measuring instruments.

I also found that the memory—the only memory—on the Minuteman I computer was a disk and that its program would be compiled on a mainframe and loaded into the disk memory. So far so good. But where was the disk?

The Minuteman was first tested in 1961, so the technology would have been frozen at 1959 or 1960 level. Disks were still relatively new and, I assumed, fairly large. So, where did it fit in the Minuteman casing?

I asked Alex Bochanek and he sent me a technical paper about the computer. It was called the D-17B and made by Autonetics subsidiary of North American Rockwell, which worked with TRW on the missile guidance system.

The paper contained the drawing that you see at the right. The disk memory was surprisingly small and it fit into the side of "cylinder." The circuitry for the computer occupies half of the cylinder section that we have on display, the other half was various power supplies.

The disk was tiny but powerful: 6,000 RPM, 68 fixed heads, 32 tracks with 128 sectors each, it stored 2,721 24 bit words. It was the only memory for the computer, aside from a few registers that were hard wired – no core, no transistor memory, no chip memory. The third picture is from our web site and shows the disk that was removed from our Minuteman computer.

The fourth picture is from Wikipedia, it shows a D17-B with the disk installed. It looks pretty much like the drawing, which was undoubtedly pre-production.

Targeting was done at SAC (Strategic Air Command) Headquarters by the Operational Targeting Program developed by TRW to execute on an IBM 709 mainframe.

Program and targeting data would be read onto the disk memory from punched paper tape at the rate of 800 5-bit characters per second from a separate paper tape reader. During operation, computer inputs and outputs were digital or analog signals to and from the guidance components on the stable platform.

When the Minuteman I was replaced by Minuteman II, the D17-B's were declared surplus and sold as general purpose minicomputers to users that had the appropriate clearances.

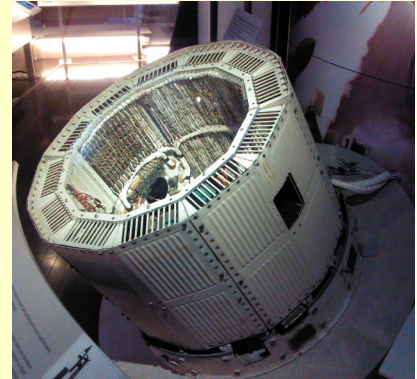

CHM Exhibit - Minuteman I Computer
Note circular hole.

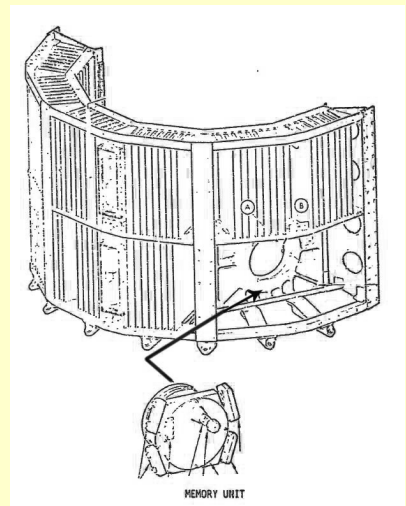

Technical drawing of disk location.



The disk from our collection (not on exhibit)

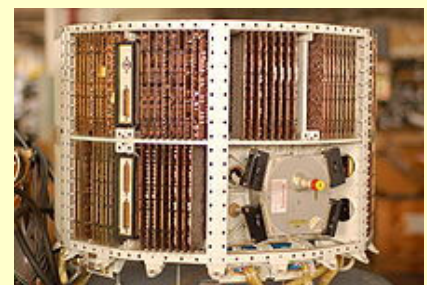

As it might look with disk installed.

ABC and the 1952 ELECTION

JIM STRICKLAND

In the last VIE, Version 2 Release 4, Wynn Dobbins wrote about the Monrobot computer used by NBC to help predict the 1952 election. The role of UNIVAC at CBS is very important and well known to all of us.

But how about ABC? Did they do anything with computers in that election?

As a network, ABC was a distant third (and Dumont was fourth). ABC had been created in 1943 from the former NBC Blue radio network after the government forced NBC to split it off. Faced with huge expenses in building a radio network, ABC was in no position to take on the additional costs of establishing a television network but, they could not afford to stay out of the new medium. In 1948 they received licenses and went on the air. But it was a slow start. In neither 1952 or 1953 did ABC have any of the top 20 TV shows. In 1953, ABC was rescued from probable bankruptcy by United Paramount Theaters.

So, in 1952 they were very underfunded and didn't have a lot of money to experiment.

ABC did use electric accounting machines from IBM to assist in their reporting. And they used IBM's (maybe it was and maybe it wasn't a computer) CPC (Card programmed Calculator). In November of 1952, IBM was still a few months away from delivering its first real computer, the "Defense Calculator," later known as the IBM 701.

But on election night, ABC broadcast from its own studio and from New York World Telegram and Sun

newsroom and they showed IBM equipment. Accounts are not clear but it is likely that the equipment included the CPC. "Lightning Fast IBM Devices to Help Speed W-T&S Televised Vote Count" was the headline on the newspaper's story about its upcoming election-night collaboration with IBM and ABC, promising that a "battery of IBM equipment of the very latest design" would be installed in the paper's city room, "nerve center of the combined newspaper and television coverage."

On the west coast, ABC used IBM equipment based at the Lockheed Aircraft Corporation in Burbank, California, for NBC coverage in the West. This was undoubtedly a CPC, which was a favorite at Lockheed and other aircraft companies.

So all three major networks had their advanced calculating/computing devices – but it was UNIVAC that really used computer forecasting techniques and ushered in the computer age.

Also, note that the advent of coast-to-coast TV had only come a year earlier. The first transcontinental TV broadcast was Sept 4, 1951 when AT&T threw the switch on the first nationwide cable and enabled a broadcast from the Japanese Peace Treaty Conference in San Francisco.

Then on November 18, Edward R. Murrow "See It Now" was the first live coast-to-coast commercial television broadcast in the US, showing a split screen view of the Brooklyn Bridge in New York City and the Bay Bridge in San Francisco.

Coming Events			
Date	Day	Time	Event
March 28	Wed.	6:00 Member Reception 7:00 Conversation 8:30 Book Signing	The Idea Factory: Bell Labs and the Great Age of American Innovation. Author Jon Gertner in conversation with KQED's Dave Iverson
June 12	Tues.	6:00 PM Member Reception 7:00 – 8:30 PM Program	Doing Well by Doing Good: A Conversation with Matthew Flannery and John Wood, moderated by KQED's Dave Iverson
Jun 27	Wed.	6:00 PM Member Reception 7:00 – 8:30 PM Program	Transforming Music: From Guitar Hero to Robotic Opera & Beyond

**Please contribute to the Computer History Museum
Volunteer Information Exchange.**

Share your stories, your interesting facts (and factoids) and your knowledge.
Send them to Jim Strickland (Jlstrick@aol.com)